

Cunningham

SINCE 1949

AIR CYLINDERS

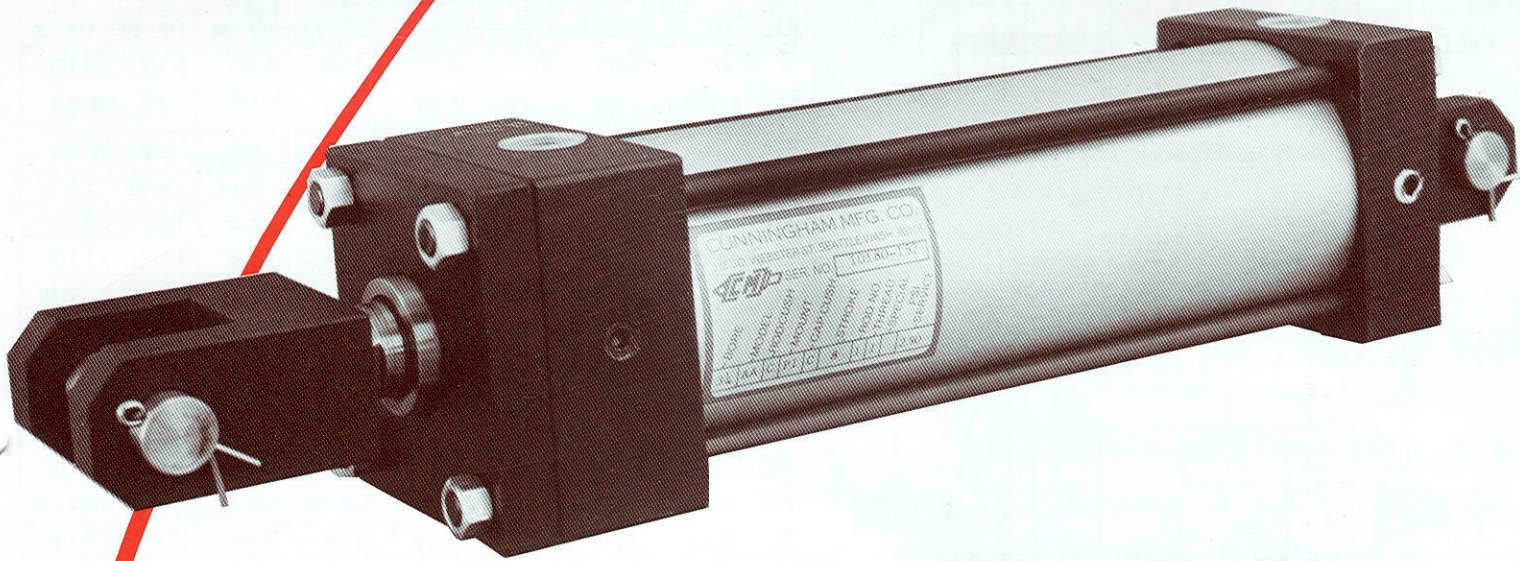

*** MODEL AA** **1½" THRU 6" BORE** **HEAVY DUTY CYLINDERS**

Cunningham Heavy Duty Cylinders are ruggedly built and are recommended where "pull" and "thrust" impact loads are above average, and where operation is continuous and under "full" load operation.

HEAVY DUTY SPECIFICATIONS

- Steel Ends
- High Tensile Steel Piston Rods (Hard Chrome Plated)
- Special Air Cylinder Grade Tubing
- High Tensile Tie Rods
- Oil Resistant Cylinder Cups and Packing
- Self-Regulating or Adjustable Cushioning
- 250 PSI Working Pressure
- Rod Wiper, Hytrel or Brass
- J I C Standard Construction and Dimensions
- NFPA Standards
- For 7" thru 22" Bore, see Catalog 299 AP

CATALOG NO. 199 AA

Cunningham Manufacturing Co.

318 SOUTH WEBSTER STREET • SEATTLE, WASHINGTON 98108 • (206) 767-3713 • FAX # 206-762-3457

Cylinder Model Numbering System

FEATURE	DESCRIPTION	SYMBOL	EXAMPLE
BORE	IN INCHES		5 AA C P1 C 56-1 3 S 250
SERIES	AIR CYLINDERS STANDARD AIR CYLINDERS, OPTIONAL ADJUSTABLE CUSHIONS AIR CYLINDERS 7-20" BORES	AA AB AP	↑ ↑ ↑
CUSHIONS HEAD END	IF NO CUSHION IS REQUIRED IF CUSHION IS REQUIRED	N C	↑
MOUNTING STYLE	PARTIAL LISTING, SEE CATALOG. CAP FIXED CLEVIS CAP FIXED PIVOT HEAD TRUNNION CAP END TRUNNION ETC.	P1 P3 T1 T2	↑
CUSHIONS CAP END	IF NO CUSHION IS REQUIRED IF CUSHION IS REQUIRED	N C	↑
STROKE	IN INCHES	—	↑
ROD SIZE	STANDARD ROD DIAMETER FIRST OVERSIZE ROD OPTION SECOND OVERSIZE ROD OPTION THIRD OVERSIZE ROD OPTION ETC.	1 2 3 4	↑
ROD THREAD	"KK" STANDARD ROD THREAD "CC" FIRST OVERSIZE THD. "KK" FEMALE THREAD ANY NON-STANDARD THD.	1 2 3 4	↑
SPECIAL	USE FOR DOUBLE ROD END, ROD BOOT, STAINLESS ROD, STOP TUBE, ETC.	S	↑
MAXIMUM WORKING PRESSURE	AIR CYLINDERS MODEL AA, AB & AP	250	↑

Force Developed By Air Cylinders

The table below may be used for any cylinder, but covers the pressure range normally used for air cylinders and air-over-oil cylinders operating from shop air lines.

Figures in the chart are forces in pounds, produced by cylinder bores on the left side of the chart operating at PSI gauge pressures shown along the top of the chart. Values were calculated by multiplying PSI gauge pressure times piston square inch area. To find cylinder

force at a pressure not shown, values in two or more columns may be combined, or, the piston area may be used as a "power factor" and multiplied times the operating PSI.

Remember to deduct rod area from piston area before multiplying by PSI when figuring cylinder force on the return stroke.

Note: Force values are theoretical. For practical use, deduct 5 to 10% for packing friction.

TABLE 2 - A: Theoretical Force From Low Pressure Cylinders (Especially Air Cylinders).

Bore Dia.	Area Sq. In.	Gauge Pressure									
		40 PSI	50 PSI	60 PSI	70 PSI	80 PSI	90 PSI	100 PSI	110 PSI	120 PSI	150 PSI
1.50	1.77	71	88	106	124	141	160	177	194	212	265
2.00	3.14	125	157	188	220	250	283	314	346	377	470
2.50	4.91	193	242	290	338	387	432	483	530	580	724
3.25	8.30	330	415	498	580	664	746	830	912	995	1245
4.00	12.57	503	628	753	880	1000	1130	1256	1380	1500	1885
5.00	19.64	785	908	1175	1375	1570	1765	1964	2160	2350	2940
6.00	28.27	1130	1410	1700	1980	2260	2550	2827	3100	3400	4220
8.00	50.27	2000	2500	3000	3500	4000	4500	5000	5500	6000	7530
10.00	78.54	3150	3900	4700	5500	6250	7000	7850	8600	9400	11,750
12.00	113.10	4530	5670	6800	7930	9060	10,200	11,310	12,450	13,600	16,900
14.00	153.94	6150	7700	9230	10,770	12,300	13,850	15,395	16,920	18,450	23,000
16.00	201.06	8040	10,050	12,060	14,070	16,085	18,095	20,105	22,115	24,125	30,160
18.00	254.47	10,170	12,720	15,265	17,810	20,350	22,900	25,445	27,990	30,535	38,170

MOUNTING ACCESSORIES

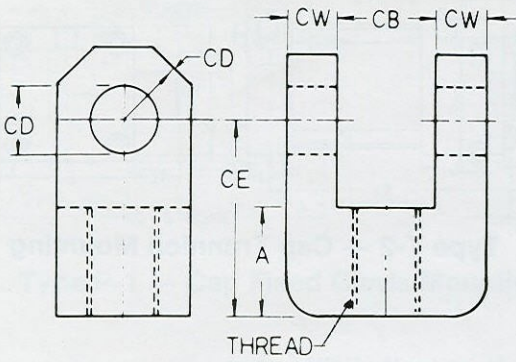

Rod End Clevis – Table 5C

Table 5-C
ROD CLEVIS DIMENSIONS

CLEVIS NO.	THREAD	A	CE	CD	CB	CW
211	7/16-20	3/4	1 1/2	1/2	13/16	1/2
212	1/2-20	3/4	1 1/2	1/2	13/16	1/2
213	5/8-18	3/4	1 1/2	1/2	13/16	1/2
221	3/4-16	1 1/8	2 1/8	3/4	1 5/16	5/8
222	7/8-14	1 1/8	2 1/8	3/4	1 5/16	5/8
223	1-14	1 1/8	2 1/8	3/4	1 5/16	5/8
221N	3/4-16	1 1/8	2 3/8	3/4	1 5/16	5/8
231N	1-14	1 5/8	3 1/8	1	1 9/16	3/4
231	1-14	1 5/8	2 15/16	1	1 9/16	3/4
232	1 1/4-12	1 5/8	2 15/16	1	1 9/16	3/4
233	1 1/2-12	1 5/8	2 15/16	1	1 9/16	3/4
241	1 1/4-12	2	3 3/4	1 3/8	2 1/16	1
242	1 1/2-12	2	3 3/4	1 3/8	2 1/16	1
243	1 3/4-12	2	3 3/4	1 3/8	2 1/16	1
251	1 1/2-12	2 1/4	4 1/2	1 3/4	2 9/16	1 1/4
252	1 3/4-12	2 1/4	4 1/2	1 3/4	2 9/16	1 1/4
253	1 7/8-12	2 1/4	4 1/2	1 3/4	2 9/16	1 1/4
254	2-12	2 1/4	4 1/2	1 3/4	2 9/16	1 1/4

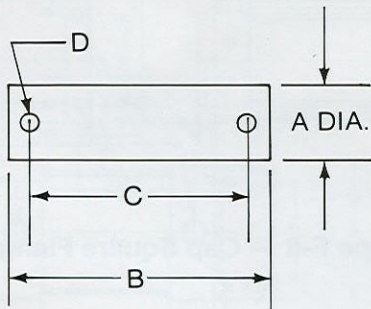
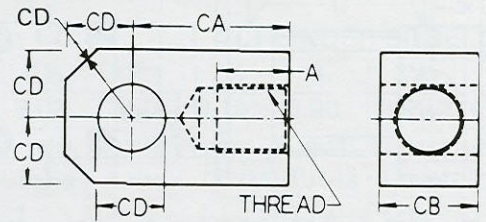

Table 5-D
CLEVIS PIN DIMENSIONS

A DIA.	PIN NO.	B	C	D
1/2"	1	2 3/8	2	9/64
3/4"	2	3 3/8	2 3/4	9/64
1"	3	3 3/4	3 1/4	13/64
1 3/8"	4	4 3/4	4 1/4	13/64
1 1/4"	5	6	5 1/2	13/64
2"	6	6	5 1/2	13/64



Rod End Eye – Table 5A

Table 5-A
PIVOT ROD EYE DIMENSIONS

EYE NO.	THREAD	A	CA	CD	CB
111	7/16-20	3/4	1 1/2	1/2	3/4
112	1/2-20	3/4	1 1/2	1/2	3/4
121	3/4-16	1 1/8	2 1/16	3/4	1 1/4
122	7/8-14	1 1/8	2 1/16	3/4	1 1/4
132	7/8-14	1 1/8	2 3/8	1	1 1/2
133	1-14	1 5/8	2 13/16	1	1 1/2
134	1 1/4-12	1 5/8	2 13/16	1	1 1/2
141	1 1/4-12	2	3 7/16	1 3/8	2
142	1 1/2-12	2	3 7/16	1 3/8	2
151	1 1/2-12	2 1/4	4	1 3/4	2 1/2
152	1 3/4-12	2 1/4	4	1 3/4	2 1/2
161	1 7/8-12	3	5	2	2 1/2

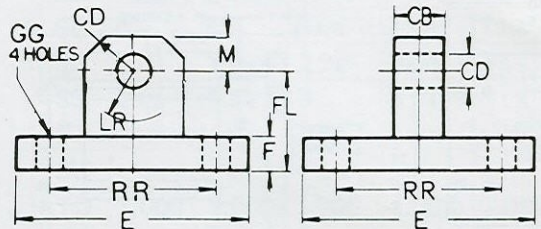

Pivot Bracket Base – Table 5B

NOTE: Clevis Bracket Base also Available.

Table 5-B
PIVOT BRACKET BASE DIMENSIONS

BRACKET NO.	CD	CB	F	FL	M	E	RR	LR	GG
1	1/2	3/4	3/8	1 1/8	1/2	2 1/2	1.63	3/4	13/32
2	3/4	1 1/4	5/8	1 7/8	3/4	3 1/2	2.55	1 1/4	17/32
3	1	1 1/2	3/4	2 1/4	1	4 1/2	3.25	1 1/2	21/32
4	1 3/8	2	7/8	3	1 3/8	5	3.82	2 1/8	21/32
5	1 3/4	2 1/2	7/8	3 1/8	1 3/4	6 1/2	4.95	2 1/4	29/32
6	2	2 1/2	1	3 1/2	2	7 1/2	5.73	2 1/2	1 1/16

Ordering Data Required for Model AA

QUANTITY

MOUNTING: Type

BORE: Diameter

STROKE: Length

ROD DIAMETER: See Table 3.

ROD THREAD: "KK" will be furnished unless otherwise specified.

CUSHIONING: Non-cushioned is standard. Self regulating cushions model AA or adjustable cushions model AB is optional.

PORT LOCATION: Standard No. 1 (top) position as indicated. 2, 3 and 4 Optional.

ROD END ATTACHMENTS: If desired.

SPECIAL FEATURES: Rod Boots, Stainless Rod, Water Service, Non-Lube etc.

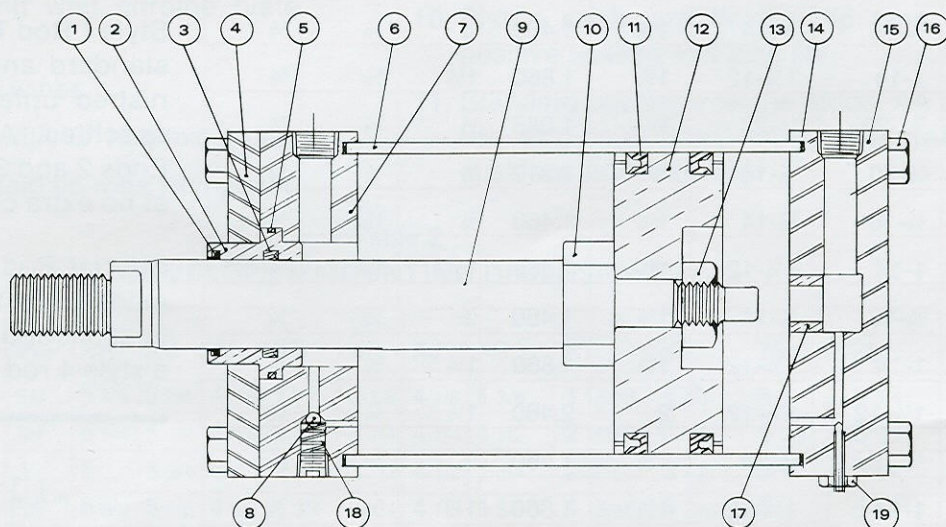

MODEL AA – PARTS LIST

AA-1	Rod wiper	AA-10	Rod cushion bushing
AA-2	Rod guide bushing	AA-11	Piston seals
AA-3	Rod packing	AA-12	Piston
AA-4	Clamp plate	AA-13	Piston nut
AA-5	Bushing seal	AA-14	Tube seals
AA-6	Cylinder tube	AA-15	Blind end cap
AA-7	Rod end cap	AA-16	Tie rod nut and tie rods
AA-8	Stainless ball (Each End)	AA-17	Blind end cushion bushing
AA-9	Piston rod	AA-18	Check valve spring (Each End)
		AB-19	Cushion Adjusting Screw (Each End Optional)

IMPORTANT: When ordering parts please give complete nameplate data as to bore, stroke, rod diameter, cushioning and serial number.

Serial numbers are found on the durable name tag and also metal stamped on front head.

Items 8, 10, 17, 18 and 19 are for cushioned cylinders only.

RECOMMENDED TIE ROD TORQUE FOR MODEL "AA" CYLINDERS

BORE	1½	2	2½	3	3¼	4	5	6
TORQUE (Foot Lbs.)	10	17	17	25	30	30	50	50
TIE ROD DIA.	¼	5/16	5/16	3/8	3/8	3/8	½	½

CMC does not authorize the approval of CMC cylinders in any of the following applications: aircraft, personnel lifts, aerial ladders, or amusement park devices.

**Table 3
ROD END DIMENSIONS**

BORE	ROD DIA. 'MM'	STD. KK THD.	OPT. CC THD.	A	B +.000 -.002	D	ROD DIM. C	BRG. DIM. V
1½	5/8	7/16-20	1/2-20	3/4	1.085	1/2	3/8	1/4
	3/4	1/2-20	5/8-18	3/4	1.210	5/8	1/2	1/4
	1"	3/4-16	7/8-14	1 1/8	1.460	7/8	1/2	1/2
2	5/8	7/16-20	1/2-20	3/4	1.085	1/2	3/8	1/4
	3/4	1/2-20	5/8-18	3/4	1.210	5/8	1/2	1/4
	1"	3/4-16	7/8-14	1 1/8	1.460	7/8	1/2	1/2
2½	1 3/8	1-14	1 1/4-12	1 5/8	1.860	1 1/8	5/8	5/8
	5/8	7/16-20	1/2-20	3/4	1.085	1/2	3/8	1/4
	3/4	1/2-20	5/8-18	3/4	1.210	5/8	1/2	1/4
3	1	3/4-16	7/8-14	1 1/8	1.460	7/8	1/2	1/4
	1 3/8	1-14	1 1/4-12	1 5/8	1.860	1 1/8	5/8	5/8
	1 3/4	1 1/4-12	1 1/2-12	2	2.460	1 1/2	3/4	1/2
3 3/4	1	3/4-16	7/8-14	1 1/8	1.460	7/8	1/2	1/4
	1 3/8	1-14	1 1/4-12	1 5/8	1.860	1 1/8	5/8	3/8
	1 3/4	1 1/4-12	1 1/2-12	2	2.460	1 1/2	3/4	1/2
4	2	1 1/2-12	1 3/4-12	2 1/4	2.585	1 1/16	7/8	1/2
	1	3/4-16	7/8-14	1 1/8	1.460	7/8	1/2	1/4
	1 3/8	1-14	1 1/4-12	1 5/8	1.860	1 1/8	5/8	3/8
5	1 3/4	1 1/4-12	1 1/2-12	2	2.460	1 1/2	3/4	1/2
	2	1 1/2-12	1 3/4-12	2 1/4	2.585	1 1/16	7/8	1/2
	2 1/2	1 7/8-12	2-12	3	3.085	2 1/16	1	5/8
6	1	3/4-16	7/8-14	1 1/8	1.460	7/8	1/2	1/4
	1 3/8	1-14	1 1/4-12	1 5/8	1.860	1 1/8	5/8	3/8
	1 3/4	1 1/4-12	1 1/2-12	2	2.460	1 1/2	3/4	1/2
6	2	1 1/2-12	1 3/4-12	2 1/4	2.585	1 1/16	7/8	1/2
	2 1/2	1 7/8-12	2-12	3	3.085	2 1/16	1	5/8
	1 3/8	1-14	1 1/4-12	1 5/8	1.860	1 1/8	5/8	1/4
6	1 3/4	1 1/4-12	1 1/2-12	2	2.460	1 1/2	3/4	3/8
	2	1 1/2-12	1 3/4-12	2 1/4	2.585	1 1/16	7/8	3/8
	2 1/2	1 7/8-12	2-12	3	3.085	2 1/16	1	5/8

PORT LOCATION:

Standard No. 1 Position as shown. Other positions, 2, 3, or 4 optional, no charge. "AN" and SAE Ports available.

**PISTON ROD THREADS
IMPORTANT:**

Style 1 Rod Thread (KK) is standard and will be furnished unless otherwise specified. Alternate Rod Ends 2 and 3 are available at no extra charge.

Special Rod Ends will be made to customer's specifications and designated as a style 4 rod end.

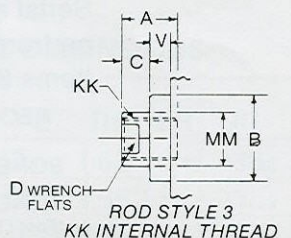
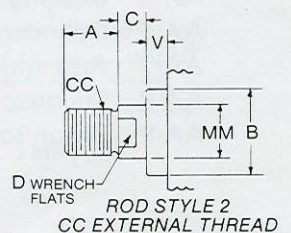
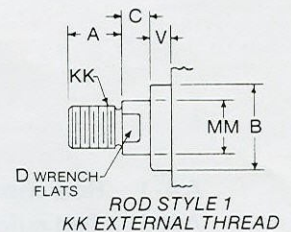

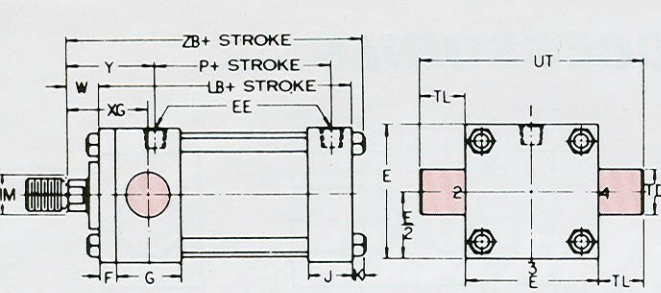

Type T-1 — Head Trunnion Mounting

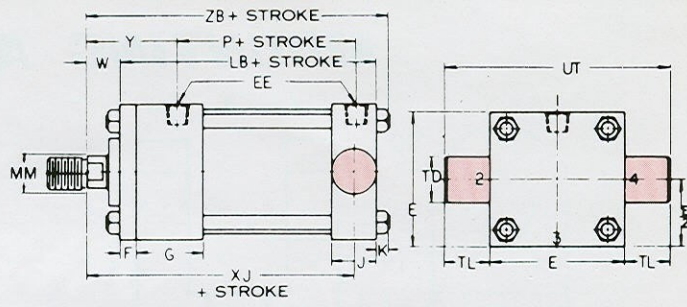

Type T-2 — Cap Trunnion Mounting

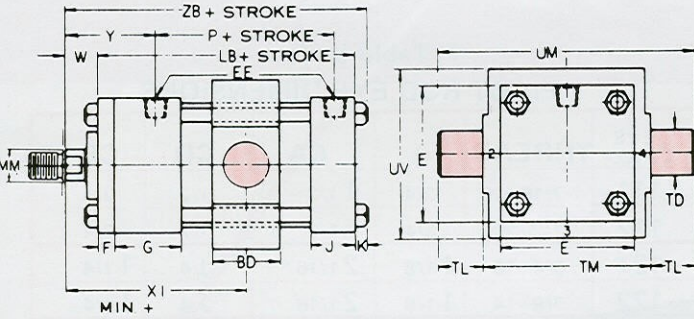

Type T-4 — Intermediate Fixed Trunnion Mounting

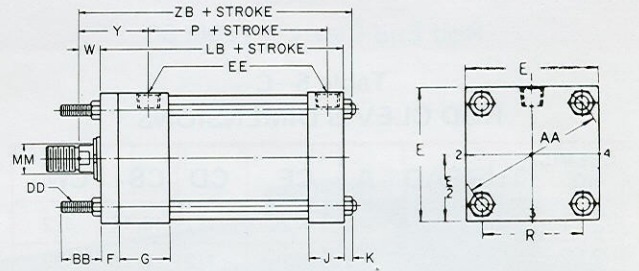

Type X3 — Head Tie Rods Extended Mounting

Type X1 — BOTH ENDS Type X2 — CAP END

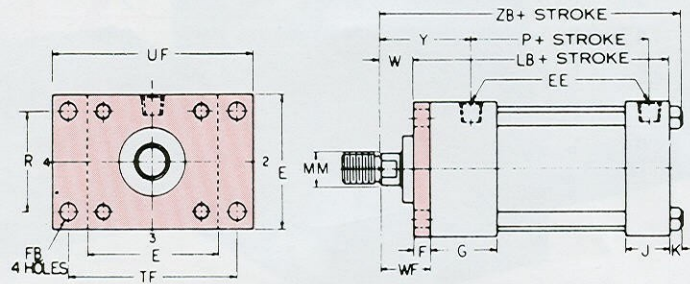

Type F-1 - Head Rectangular Flange Mounting

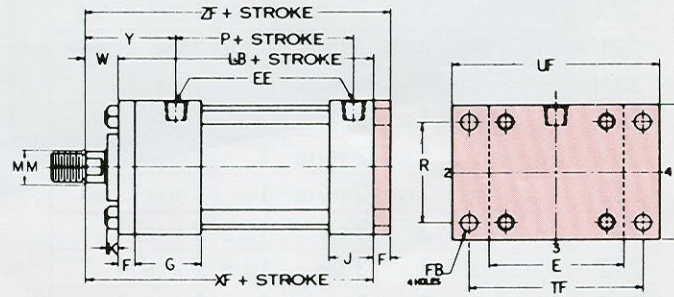

Type F-2 — Cap Rectangular Flange Mounting

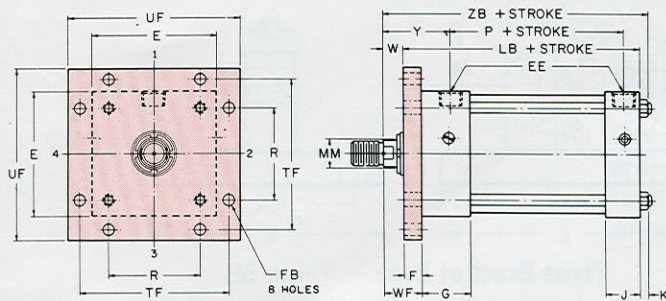

Type F-5 — Head Square Flange

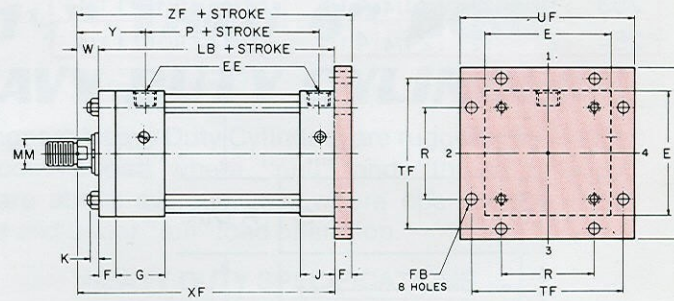

Type F-6 — Cap Square Flange

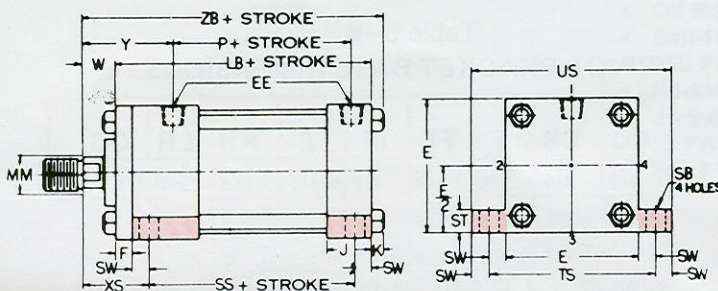

Type S-2 — Side Lugs Mounting

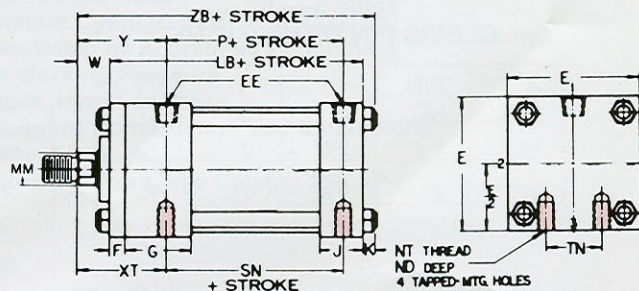

Type S-4 — Side Tapped Mounting

Table 1
ENVELOPE & MOUNTING DIMENSIONS

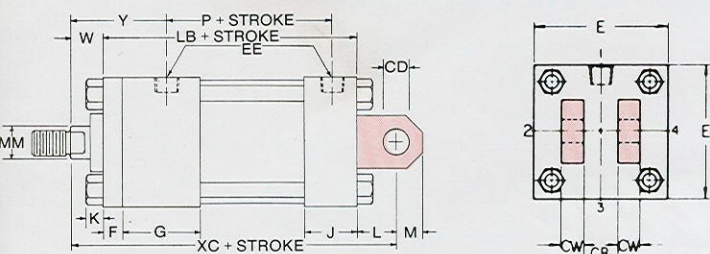

Type P-1 — Cap Fixed Clevis Mounting

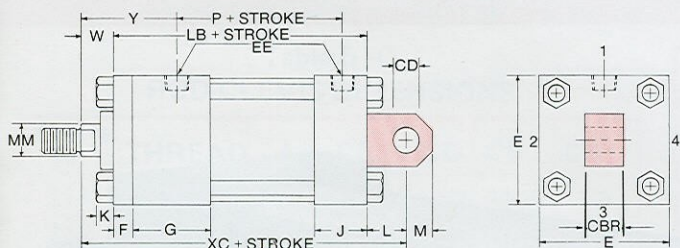

Type P-3 — Cap Fixed Pivot Available

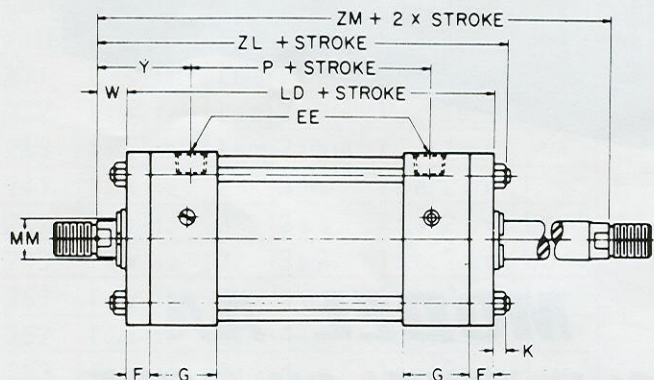

Type DRE — Basic Double Rod Extension

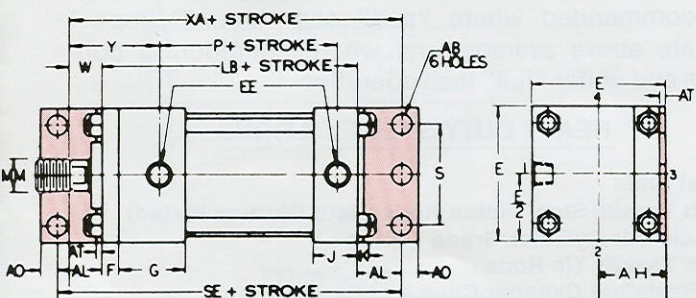

Type S-1 — Side End Angles Mounting

CYLINDER BORE

	1½	2	2½	3	3¼	4	5	6
AA	2.02	2.60	3.10	3.90	3.90	4.70	5.80	6.90
AB	7/16	7/16	7/16	9/16	9/16	9/16	11/16	13/16
AH	13/16	1 7/16	1 5/8	1 13/16	1 15/16	2 1/4	2 3/4	3 1/4
AL	1	1	1	1 1/4	1 1/4	1 1/4	1 3/8	1 3/8
AO	3/8	3/8	3/8	1/2	1/2	1/2	5/8	5/8
AT	1/8	1/8	1/8	1/8	1/8	1/8	3/16	3/16
BB	1	1 1/8	1 1/8	1 3/8	1 3/8	1 3/8	1 13/16	1 13/16
BD	1 1/4	1 1/2	1 1/2	2	2	2	2	2 1/2
CB	13/16	13/16	13/16	1 5/16	1 5/16	1 5/16	1 5/16	1 9/16
CD	3/4	3/4	3/4	1 1/4	1 1/4	1 1/4	1 1/4	1 1/2
±CD	.501	.501	.501	.751	.751	.751	.751	1.001
CW	1/2	1/2	1/2	5/8	5/8	5/8	5/8	3/4
DD	1/4-28	5/16-24	5/16-24	3/8-24	3/8-24	3/8-24	1/2-20	1/2-20
E	2	2 1/2	3	3 1/2	3 3/4	4 1/2	5 1/2	6 1/2
EE	3/8	3/8	3/8	1/2	1/2	1/2	1/2	3/4
NPT(F)								
F	3/8	3/8	3/8	5/8	5/8	5/8	5/8	3/4
FB	5/16	3/8	3/8	7/16	7/16	7/16	9/16	9/16
G	1 1/2	1 1/2	1 1/2	1 3/4	1 3/4	1 3/4	1 3/4	2
J	1	1	1	1 1/4	1 1/4	1 1/4	1 1/4	1 1/2
K	1/4	5/16	5/16	3/8	3/8	3/8	7/16	7/16
L	3/4	3/4	3/4	1 1/4	1 1/4	1 1/4	1 1/4	1 1/2
LB	4	4	4 1/8	4 7/8	4 7/8	4 7/8	5 1/8	5 3/4
LD	4 7/8	4 7/8	5	6	6	6	6 1/4	7
M	1/2	1/2	1/2	3/4	3/4	3/4	3/4	1
ND	3/8	3/8	1/2	3/4	3/4	3/4	15/16	1 1/8
NT	1/4-20	5/16-18	3/8-16	1/2-13	1/2-13	1/2-13	5/8-11	3/4-10
P	2 1/4	2 1/4	2 3/8	2 5/8	2 5/8	2 5/8	2 7/8	3 1/8
R	1.43	1.84	2.19	2.75	2.76	3.32	4.10	4.88
S	1 1/4	1 3/4	2 1/4	2 1/2	2 3/4	3 1/2	4 1/4	5 1/4
SB	7/16	7/16	7/16	9/16	9/16	9/16	13/16	13/16
SE	6	6	6 1/8	7 3/8	7 3/8	7 3/8	7 7/8	8 1/2
SN	2 1/4	2 1/4	2 3/8	2 5/8	2 5/8	2 5/8	2 7/8	3 1/8
SS	2 7/8	2 7/8	3	3 1/4	3 1/4	3 1/4	3 1/8	3 5/8
ST	1/2	1/2	1/2	3/4	3/4	3/4	1	1
SW	3/8	3/8	3/8	1/2	1/2	1/2	11/16	11/16
*TD	1.000	1.000	1.000	1.000	1.000	1.000	1.000	1.375
TF	2 3/4	3 3/8	3 7/8	4 1/2	4 11/16	5 7/16	6 5/8	7 5/8
TL	1	1	1	1	1	1	1	1 3/8
TM	2 1/2	3	3 1/2	4 1/2	4 1/2	5 1/4	6 1/4	7 5/8
TN	5/8	7/8	1 1/4	1 1/2	1 1/2	2 1/16	2 11/16	3 1/4
TS	2 3/4	3 1/4	3 3/4	4 1/2	4 3/4	5 1/2	6 7/8	7 7/8
UF	3 3/8	4 1/8	4 5/8	5 1/2	5 1/2	6 1/4	7 5/8	8 5/8
UM	4 1/2	5	5 1/2	6 1/2	6 1/2	7 1/4	8 1/4	10 3/8
US	3 1/2	4	4 1/2	5 1/2	5 3/4	6 1/2	8 1/4	9 1/4
UT	4	4 1/2	5	5 1/2	5 3/4	6 1/2	7 1/2	9 1/4
UV	2 1/2	3	3 1/2	4 1/4	4 1/4	5	6	7

MODEL AA: Non-Cushioned Standard. Self regulating cushions are optional.

MODEL AB: Adjustable cushions are standard.

ALL DIMENSIONS IN INCHES

± .006 — .000

* Oversize Trunnion Journals available on request.

Journal Tolerance +.000" Standard
-.002"

Cunningham MODEL AA AIR CYLINDERS

1 1/2" THRU 6" BORE

(7" Bore and Larger, see Catalog 299 AP)

QUALITY FEATURES

1. 660 bronze rod bearing.
2. 100,000 PSI min. yield, hard chrome plated rod.
3. Heat treated aluminum cylinder tubing anodized O.D. and hard coated on I.D. Honed steel tubing with chrome plate I.D. optional.
4. Hytrel or brass rod wiper.
5. Urethane rod seal with 'O' ring expander.
6. 100,000 psi min. yield tie rods with plated tie rod nuts.
7. Precision finished steel end caps machined on CNC turret lathes.
8. Non-ferrous pistons for excellent wear characteristics.
9. Oversize cushion ball checks standard.
10. Piston seals are flexible lip type for positive sealing and long life.
11. Standard cushions on the Model AA are the self-regulating type, adjustable cushions are available.

Table 2
ENVELOPE & MOUNTING DIMENSIONS

Bore	Rods	Y	W	XA	XC	XF	XG	Min. XI	XJ	XS	XT	ZB	ZF	ZL	ZM
1 1/2	5/8*	1 15/16	5/8	5 5/8	5 3/8	4 5/8	1 3/4	3 1/8	4 1/8	1 3/8	1 15/16	4 7/8	5	5 3/4	6 1/8
	3/4	2 1/16	3/4	5 3/4	5 1/2	4 3/4	1 7/8	3 1/4	4 1/4	1 1/2	2 1/16	5	5 1/8	5 7/8	6 3/8
	1**	2 5/16	1	6	5 3/4	5	2 1/8	3 1/2	4 1/2	1 3/4	2 5/16	5 1/4	5 3/8	5 3/4	6 7/8
2	5/8*	1 15/16	5/8	5 5/8	5 3/8	4 5/8	1 3/4	3 1/4	4 1/8	1 3/8	1 15/16	4 15/16	5	5 13/16	6 1/8
	3/4	2 1/16	3/4	5 3/4	5 1/2	4 3/4	1 7/8	3 3/8	4 1/4	1 1/2	2 1/16	5 1/16	5 1/8	5 15/16	6 3/8
	1	2 5/16	1	6	5 3/4	5	2 1/8	3 5/8	4 1/2	1 3/4	2 5/16	5 5/16	5 3/8	6 3/16	6 7/8
	1 3/8**	2 9/16	1 1/4	6 1/4	6	5 1/4	2 3/8	3 7/8	4 3/4	2	2 9/16	5 9/16	5 5/8	6 7/16	7 3/8
2 1/2	5/8*	1 15/16	5/8	5 3/4	5 1/2	4 3/4	1 3/4	3 1/4	4 1/4	1 3/8	1 15/16	5 1/16	5 1/8	5 15/16	6 1/4
	3/4	2 1/16	3/4	5 7/8	5 5/8	4 7/8	1 7/8	3 3/8	4 3/8	1 1/2	2 1/16	5 3/16	5 1/4	6 1/16	6 1/2
	1	2 5/16	1	6 1/8	5 7/8	5 1/8	2 1/8	3 5/8	4 5/8	1 3/4	2 5/16	5 7/16	5 1/2	6 5/16	7
	1 3/8	2 9/16	1 1/4	6 3/8	6 1/8	5 3/8	2 3/8	3 7/8	4 7/8	2	2 9/16	5 11/16	5 3/4	6 9/16	7 1/2
3 & 3 1/4	1*	2 7/16	3/4	6 7/8	6 7/8	5 5/8	2 1/4	4 1/8	5	1 7/8	2 7/16	6	6 1/4	7 1/8	7 1/2
	1 3/8	2 11/16	1	7 1/8	7 1/8	5 7/8	2 1/2	4 3/8	5 1/4	2 1/8	2 11/16	6 1/4	6 1/2	7 3/8	8
	1 3/4	2 15/16	1 1/4	7 3/8	7 3/8	6 1/8	2 3/4	4 5/8	5 1/2	2 3/8	2 15/16	6 1/2	6 3/4	7 5/8	8 1/2
4	2	3 1/16	1 3/8	7 1/2	7 1/2	6 1/4	2 7/8	4 3/4	5 5/8	2 1/2	3 1/16	6 5/8	6 7/8	7 3/4	8 3/4
	1*	2 7/16	3/4	6 7/8	6 7/8	5 5/8	2 1/4	4 1/8	5	1 7/8	2 7/16	6	6 1/4	7 1/8	7 1/2
	1 3/8	2 11/16	1	7 1/8	7 1/8	5 7/8	2 1/2	4 3/8	5 1/4	2 1/8	2 11/16	6 1/4	6 1/2	7 3/8	8
	1 3/4	2 15/16	1 1/4	7 3/8	7 3/8	6 1/8	2 3/4	4 5/8	5 1/2	2 3/8	2 15/16	6 1/2	6 3/4	7 5/8	8 1/2
	2	3 1/16	1 3/8	7 1/2	7 1/2	6 1/4	2 7/8	4 3/4	5 5/8	2 1/2	3 1/16	6 5/8	6 7/8	7 3/4	8 3/4
5	2 1/2	3 5/16	1 5/8	7 3/4	7 3/4	6 1/2	3 1/8	5	5 7/8	2 3/4	3 5/16	6 7/8	7 1/8	8	9 1/4
	1*	2 7/16	3/4	6 7/8	6 7/8	5 5/8	2 1/4	4 1/8	5 1/4	2 1/16	2 7/16	6 5/16	6 1/2	7 7/16	7 3/4
	1 3/8	2 11/16	1	7 1/2	7 3/8	6 1/8	2 1/2	4 3/8	5 1/2	2 5/16	2 11/16	6 9/16	6 3/4	7 11/16	8 1/4
	1 3/4	2 15/16	1 1/4	7 3/4	7 5/8	6 3/8	2 3/4	4 5/8	5 3/4	2 9/16	2 15/16	6 13/16	7	7 15/16	8 3/4
	2	3 1/16	1 3/8	7 7/8	7 3/4	6 1/2	2 7/8	4 3/4	5 7/8	2 11/16	3 1/16	6 15/16	7 1/8	8 1/16	9
6	2 1/2	3 5/16	1 5/8	8 1/8	8	6 3/4	3 1/8	5	6 1/8	2 15/16	3 5/16	7 3/16	7 3/8	8 5/16	9 1/2
	1 3/8*	2 13/16	7/8	8	8 1/8	6 5/8	2 5/8	4 7/8	5 7/8	2 5/16	2 13/16	7 1/16	7 3/8	8 5/16	8 3/4
	1 3/4	3 1/16	1 1/8	8 1/4	8 3/8	6 7/8	2 7/8	5 1/8	6 1/8	2 9/16	3 1/16	7 5/16	7 5/8	8 9/16	9 1/4
	2	3 3/16	1 1/4	8 3/8	8 1/2	7	3	5 1/4	6 1/4	2 11/16	3 3/16	7 7/16	7 3/4	8 11/16	9 1/2
6	2 1/2	3 7/16	1 1/2	8 5/8	8 3/4	7 1/4	3 1/4	5 1/2	6 1/2	2 15/16	3 7/16	7 11/16	8	8 15/16	10

*Standard Rod Diameter **Cushion Not Available Rod End